

FST-SQ-IO 驱动器使用手册

FST-SQ-IO driver user manual

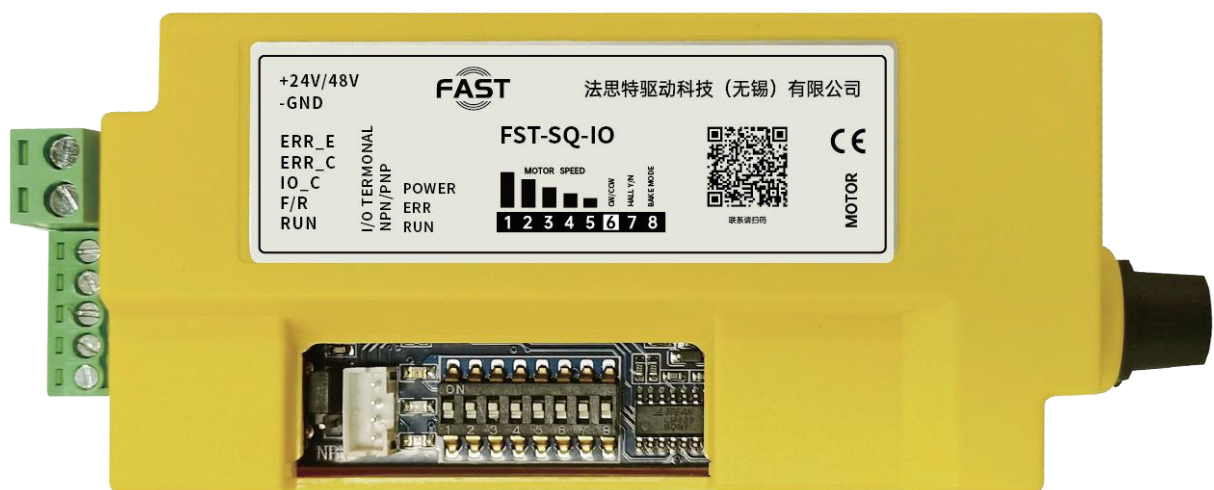

目录

一、手册功能 Manual function	- 3 -
二、注意事项 Attention notes	- 3 -
三、环境要求 Environmental Requirements	- 3 -
四、名词解释 Definition of terms	- 3 -
① 直流无刷电机 Brush-less DC Motor	- 3 -
② 霍尔传感器 Hall sensor	- 3 -
③ LED	- 4 -
④ PNP/NPN	- 4 -
⑤ 速度开环/闭环 Speed open-loop/closed-loop	- 4 -
五、驱动器主要参数 Main parameter of Driver	- 4 -
六、主要功能 Main functions	- 5 -
七、驱动卡硬件功能说明 Driver Card Hardware Specifications	- 5 -
1. 电源端口 Power Port	- 6 -
2. I/O 功能定义 I/O Functional Definition	- 6 -
1) 正反转设定表 Forward and Reverse Setting	- 6 -
2) IO 二段速设定表 IO Two-Stage Speed Setting Description	- 6 -
3) 故障口设定表 Fault Port Configuration Description	- 6 -
4. PNP\NPN 切换 PNP\NPN Switching	- 7 -
5. 状态指示灯 LED Status	- 7 -
1) 故障对照表 Fault Reference Table	- 7 -
6. 功能配置 8 位拨码开关设定	- 8 -
1) 速度拨码设定表 Speed DIP Switch Setting Table	- 8 -
八、接线 Wiring	- 10 -
1. PNP 模式控制接线图 PNP Mode Control Wiring Diagram	- 10 -
2. NPN 模式控制接线图 PNP Mode Control Wiring Diagram	- 10 -
九、外形尺寸、安装孔位 External dimensions, mounting hole positions	- 11 -
1. 外形尺寸 External dimensions	- 11 -
2. 安装孔尺寸 Mounting hole dimensions	- 11 -



一、手册功能 Manual function

- ★ 该手册用于帮助客户快速完成对法思特电动辊筒驱动器 FST-T-IO 的快速安装，设定和使用。
This manual is designed to assist customers in the rapid installation, configuration, and operation of the Fast Motor Drive Roller(MDR) Driver FST-T-IO.

二、注意事项 Attention notes

- ★ 不要在爆炸性环境、可燃性气体环境、腐蚀性环境、接触水的场所、可燃物旁边使用。以免发生爆炸、受伤、火等事件。
Do not use in explosive atmospheres, flammable gas environments, corrosive conditions, locations exposed to water, or near combustible materials. This prevents incidents such as explosions, injury, or fire.
- ★ 进行设置、连接、运行、操作、检查、故障诊断作业时，一定是要具备合适资格的人员施行。
All installation, connection, operation, inspection, and fault diagnosis tasks must be performed by suitably qualified personnel.
- ★ 请不要在通电状态下进行移动、设置、连接、检查等作业。作业时，一定要切断电源后再作业。
Never move, install, connect, or inspect equipment while it is powered on. Always disconnect the power supply before undertaking any work.
- ★ 供电线径要大于 1 平方线。需要加延长线使用需要咨询技术人员，延长线过长或周围干扰源多都会影响正常使用。
The power supply cable cross-section must exceed 1 square millimetre. Consult technical personnel before using extension cables, as excessive length or numerous surrounding interference sources may impair normal operation.

三、环境要求 Environmental Requirements

- ★ 室内（没有直射阳光、雨水、水滴、没有结露及腐蚀性气体的场所）
Indoor locations (free from direct sunlight, rain, water droplets, condensation, and corrosive gases)

四、名词解释 Definition of terms

① 直流无刷电机 Brush-less DC Motor

- ★ 电机由永磁转子和绕有线圈的定子组成，这种电机具有结构简单、可靠性高、稳定性好、效率高、适应性强等优点，因此得到了广泛的应用。
Comprising a permanent magnet rotor and a stator wound with coils, this motor offers advantages including simple construction, high reliability, excellent stability, high efficiency, and strong adaptability. Consequently, it has found widespread application.

② 霍尔传感器 Hall sensor

- ★ 由于无刷电机取消了碳刷，因此电机自身不能运行，需要依靠外部的驱动卡运行，霍尔传感器就是安装在电机内部用来向驱动卡反馈位置信号的器件。
As brush-less motors eliminate carbon brushes, they cannot operate independently and require an external driver card for operation. The Hall sensor is a device installed within the motor to provide position feedback signals to the driver card.

③ **LED**

★ 发光二极管，用来指示驱动系统的状态。

Light-emitting diode, used to indicate the status of the drive system. Light-emitting diode, used to indicate the status of the drive system.

④ **PNP/NPN**

有效控制信号的逻辑电平：NPN 表示低电平有效，即接 DC-有效；PNP 表示高电平有效，即接 DC+有效。

Effective control signal logic levels: NPN denotes active-low logic, i.e. connected to DC- is active; PNP denotes active-high logic, i.e. connected to DC+ is active.

⑤ **速度开环/闭环 Speed open-loop/closed-loop**

1) 速度开环：滚筒转速随负载加大而降低

Speed open-loop: Drum rotational speed decreases as load increases.

2) 速度闭环：滚筒额定功率以内时，滚筒转速不随负载变化而变化。

Speed closed-loop: Within the drum's rated power capacity, rotational speed remains constant regardless of load variation.

五、驱动器主要参数 Main parameter of Driver

项目 Item	规格 Specification
驱动器型号 Driver Model	FST-SQ-IO
额定输入电压 Rated input voltage	24V(±5%)
额定运行电流 Rated operate current	2.5A(电辊筒功率≤60W) 2.5A (Drum motor power≤60W) 4.2A(电辊筒功率 80~100W) 4.2A (Drum motor power:20-100W)
启动输出电流 Start-up output current	5A(电辊筒功率≤60W) 5A (Drum motor power≤60W) 9A(电辊筒功率 80~100W) 9A (Drum motor power:20-100W)
驱动器尺寸 Driver dimensions	长度 115*宽度 52mm Length 115* width 52mm
驱动器通讯方式 Driver communication method	I/O
使用环境温度 Operating ambient temperature	-20°C~40°C
使用环境湿度 Operating ambient humidity	75% 以下(无结露) Below 75% (no condensation)
电机接口 Motor interface	F10B-9M (9 芯扁头防水 9-core flat-head waterproof)

六、主要功能 Main functions

- ★ 支持 PNP\NPN 模式切换 Supports PNP/NPN mode switching
- ★ 32 档速度速度设置 32-speed settings
- ★ 支持普通刹车和伺服刹车 Supports standard braking and servo braking
- ★ 支持有感无感模式切换 Supports inductive/non-inductive mode switching
- ★ 2 档 I/O 信号速度切换 2-speed I/O signal switching
- ★ 故障信号输出 Fault signal output
- ★ 9 芯扁头防水电辊筒接口 9-pin flat waterproof motor drum interface
- ★ 最大支持电动辊筒功率 160W Maximum supported electric roller power: 160W

七、驱动卡硬件功能说明 Driver Card Hardware Specifications

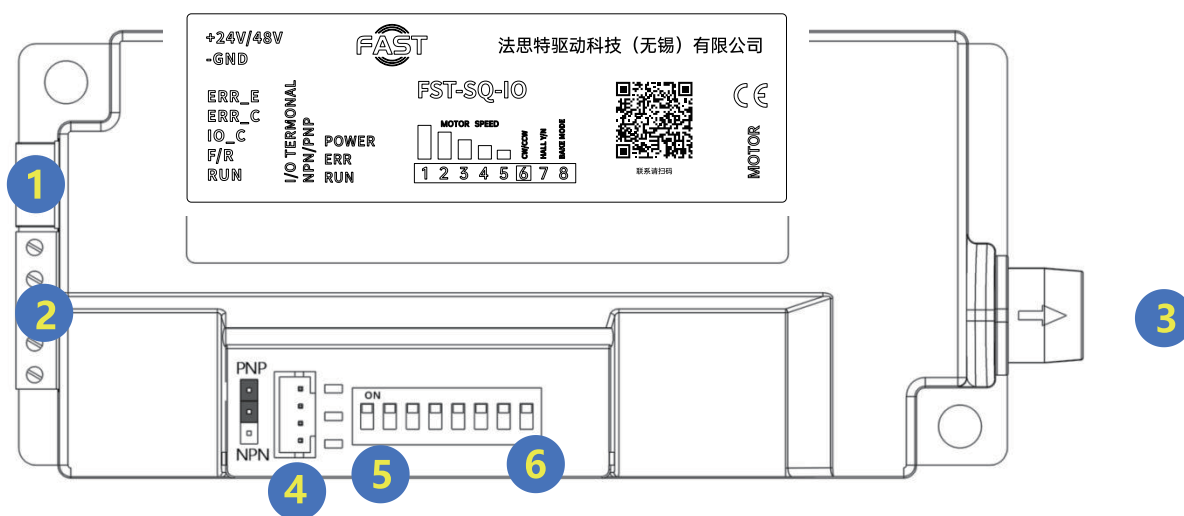

位置 Position	功能描述 Function description
1	电源接线端子 Power supply terminal block
2	I/O 接线端子 I/O terminal block
3	9 芯扁头防水接口 (匹配 50、60 系列电辊筒) 9 core flat waterproof interface (match to 50/60 series motor drum)
4	PNP\NPN 切换跳帽 PNP/NPN Switching Jumper Cap
5	LED 状态指示灯 LED Status Indicator
6	8 位功能拨码开关 8-Position Function DIP Switch

1. 电源端口 Power Port

序号 No.	端口 1 Port 1	端口 2 Port 2	备注 Remarks
1	+24/48V	-GND	电压范围: 18~52V (根据电辊筒的工作电压选择 24、48V) Voltage range: 18~52V (select 24V or 48V based on the operating voltage of the electric roller drum) 母线最大电流 10A Maximum bus bar current: 10A 供电线径≥1mm ² , 开关电源≥240W Power supply cable cross-section ≥1mm ² , Switching power supply ≥240W.
2	正极电源线接口 Negative terminal power cable connector	负极电源线接口 Positive terminal power cable connector	

2. I/O 功能定义 I/O Functional Definition

编号 No.	名称 Name	描述 Description
1	ERR_E	故障信号输出 (详见接法) Fault signal output (see wiring details)
2	ERR_C	
3	IO_C	二段速 (需要与 RUN 信号同时配合使用) Two-speed operation (requires simultaneous use with RUN signal)
4	F/R	反转 Reverse rotation
5	RUN	正转 Forward rotation

1)正反转设定表 Forward and Reverse Setting

RUN	F/R	描述 Description
1	0	正转 Reverse rotation
0	1	反转 Forward rotation

2)IO 二段速设定表 IO Two-Stage Speed Setting Description

RUN	IO_C	描述 Description
1	0	电辊筒以 100%的拨码设定速度运行 The motor drum operates at 100% of the dip switch-set speed.
1	1	电辊筒以 30%的拨码设定速度运行 The motor drum operates at 30% of the dip switch-set speed.
0	0	停止运行 Stop operations

3)故障口设定表 Fault Port Configuration Description

模式 Model	ERR_E	ERR_C	描述 Description
PNP	接 PLC 的 X、I 点 Connect to PLC X and I points	+24V	正常此端口输出 0V, 报警时输出+24V ERR_A: Normal output 0V; alarm output +24V
NPN	0V(GND)	接 PLC 的 X、I 点 Connect to PLC X and I points	正常此端口输出+24V, 报警时输出 0V ERR_A: Normal output +24V; alarm output 0V

3. 9 芯扁头防水接口 9 Core Flat Waterproof Interface



4. PNP\NPN 切换 PNP\NPN Switching

模式 Model	跳帽位置 Jump cap position		控制信号 Control Signal
PNP		跳帽接上面两个针脚 Jumper cap connected to the top two pins	+24V
NPN		跳帽接下面两个针脚 Jumper cap connected to the bottom two pins	0V

5. 状态指示灯 LED Status

位置 Position	描述 Description	备注 Remarks
中间 Middle	故障信号灯 Fault signal light	详见故障对照表 See the fault reference table for details.
最下方 Bottom	运行信号灯 Operating signal light	有运行信号时常亮，无运行信号时熄灭。 It remains illuminated when an operational signal is present and extinguishes when no operational signal is present.

1) 故障对照表 Fault Reference Table

灯状态 Light status	故障类型 Fault type	说明 Description	处理方法 Treatment methods
闪 1 下，停 2 秒。循环 Flash once, pause for two seconds. Repeat.	电源异常 Power supply anomaly	电源欠压或过压，超出可工作范围 Power supply under voltage or over voltage, exceeding operational range	检测电压 Detection voltage
闪 2 下，停 2 秒。循环 Flash twice, pause for two seconds. Repeat.	霍尔异常 Hall sensor malfunction	传感器受到电磁干扰，状态异常或线束、接头破损 Sensor subjected to electromagnetic interference, abnormal status or damaged wiring harness/connectors	检查周围干扰源、驱动器和电辊筒的线束和接口。 Inspect surrounding interference sources, driver and drum motor wiring harnesses and interfaces.
闪 3 下，停 2 秒。循环 Flash three times, pause for two seconds. Repeat.	电机堵转 Motor stall rotation	电辊筒无法转动，过大负载或被卡住 Drum motor unable to rotate, excessive load or jammed	检查有没有超载或其他机械卡死 Check for overload or other mechanical jamming

闪 4 下, 停 2 秒。循环 Flash four times, pause for two seconds. Repeat.	过流 Over current	电辊筒短路或驱动卡 MOS 损坏 Drum motor short circuit or damaged drive MOSFET	检查电辊筒工况、接线。替换新驱动器测试 Inspect drum motor operating condition and wiring. Test with replacement driver
闪 5 下, 停 2 秒。循环 Flash five times, pause for two seconds. Repeat.	过热 Over heat	电辊筒温度高于保护阈值 Drum motor temperature exceeds protection threshold	检查电辊筒工况 Inspect drum motor operating condition
闪 > 5 下, 停 2 秒。循环 Flash five times, pause for two seconds. Repeat.	其他 Others		检查电辊筒工况 Inspect drum motor operating condition

6. 功能配置 8 位拨码开关设定

Function Configuration via 8-Bit DIP Switch Settings

名称 Name	功能 Function
SW1-5	32 档调速拨码, 详见速度拨码设定表 32-step speed adjustment DIP switch, refer to the speed DIP switch configuration table for details
SW6	默认运行方向切换 Default running direction toggle
SW7	有感/无感切换, 默认霍尔模式拨码 OFF。霍尔故障后可切换到 ON 临时应急使用。 Sensor/sensor-less mode toggle. Default Hall mode DIP switch set to OFF. Switched to ON for temporary emergency use following Hall sensor failure.
SW8	刹车模式, OFF 为电子刹车, ON 为伺服刹车 Brake mode: OFF indicates electronic braking, ON indicates servo braking

1) 速度拨码设定表 Speed DIP Switch Setting Table

拨码值 DIP switch setting	SW1	SW2	SW3	SW4	SW5	100%速度 100%speed	30%速度 30%speed
1	OFF	OFF	OFF	OFF	OFF	18%	5%
2	ON	OFF	OFF	OFF	OFF	18%	6%
3	OFF	ON	OFF	OFF	OFF	19%	6%
4	ON	ON	OFF	OFF	OFF	19%	6%
5	OFF	OFF	ON	OFF	OFF	20%	6%
6	ON	OFF	ON	OFF	OFF	20%	6%
7	OFF	ON	ON	OFF	OFF	21%	6%
8	ON	ON	ON	OFF	OFF	22%	7%
9	OFF	OFF	OFF	ON	OFF	22%	7%
10	ON	OFF	OFF	ON	OFF	23%	7%
11	OFF	ON	OFF	ON	OFF	24%	7%
12	ON	ON	OFF	ON	OFF	25%	7%
13	OFF	OFF	ON	ON	OFF	26%	8%
14	ON	OFF	ON	ON	OFF	27%	8%
15	OFF	ON	ON	ON	OFF	28%	8%



16	ON	ON	ON	ON	OFF	29%	9%
17	OFF	OFF	OFF	OFF	ON	32%	10%
18	ON	OFF	OFF	OFF	ON	33%	10%
19	OFF	ON	OFF	OFF	ON	35%	10%
20	ON	ON	OFF	OFF	ON	37%	11%
21	OFF	OFF	ON	OFF	ON	39%	12%
22	ON	OFF	ON	OFF	ON	41%	12%
23	OFF	ON	ON	OFF	ON	44%	13%
24	ON	ON	ON	OFF	ON	47%	14%
25	OFF	OFF	OFF	ON	ON	50%	15%
26	ON	OFF	OFF	ON	ON	54%	16%
27	OFF	ON	OFF	ON	ON	58%	17%
28	ON	ON	OFF	ON	ON	64%	19%
29	OFF	OFF	ON	ON	ON	70%	21%
30	ON	OFF	ON	ON	ON	78%	23%
31	OFF	ON	ON	ON	ON	87%	26%
32	ON	ON	ON	ON	ON	100%	30%

注：电动辊筒速度代码为 100%速度，如 FST-D50-500-18-T-P-N-24-C1-X1-T-60，速度代码 18 就代表此款辊筒 100%速度约为 18m/min 再看 RUN、IO_C 的状态确定二段速挡位，比如 RUN、IO_C 同时给信号，那就是按 30%那列的速度数据。

再结合拨码状态，比如此时拨码状态是 SW1~SW5 全 ON，那参照速度拨码设置表此时对应的拨码值是 32，那这款电辊筒此时的速度大概为 $30\% \times 18 = 5.4\text{m/min}$ 。

Note: The speed code for electric rollers denotes 100% speed. For example, in the model FST-D50-500-18-T-P-N-24-C1-X1-T-60, the speed code 18 indicates that this roller's 100% speed is approximately 18m/min.

Next, determine the two-stage speed setting based on the RUN and IO_C status. For instance, if both RUN and IO_C signals are present simultaneously, the speed data from the 30% column applies.

Combine this with the DIP switch settings. For instance, if DIP switches SW1 to SW5 are all ON, the corresponding DIP switch value in the speed setting table is 32. Thus, the speed of this electric roller would be approximately $30\% \times 18 = 5.4\text{ m/min}$.

八、接线 Wiring

1、PNP 模式控制接线图 PNP Mode Control Wiring Diagram

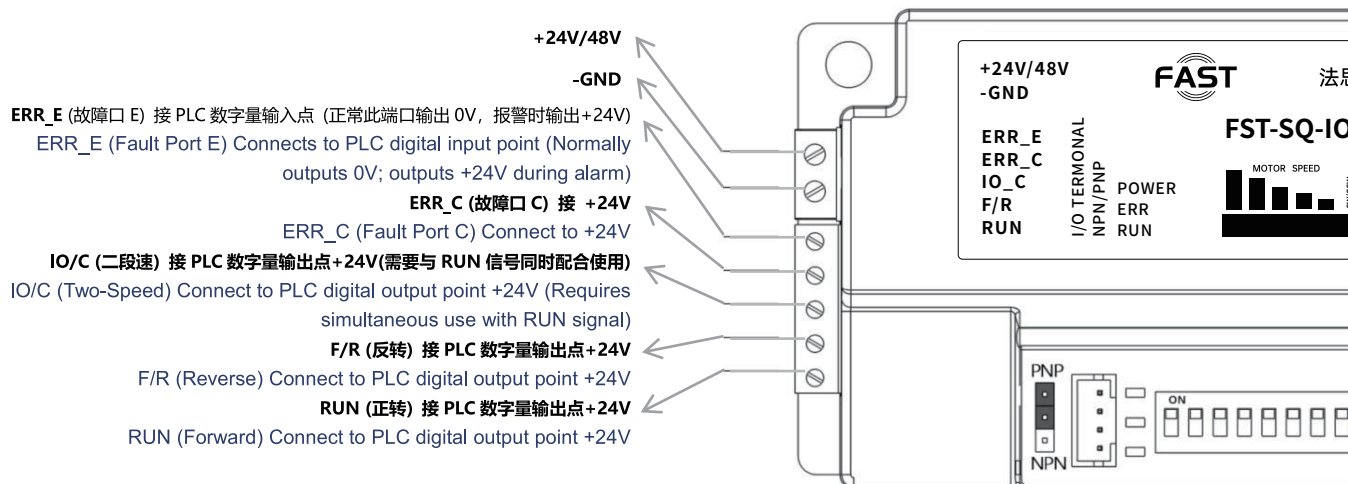

2. NPN 模式控制接线图 PNP Mode Control Wiring Diagram

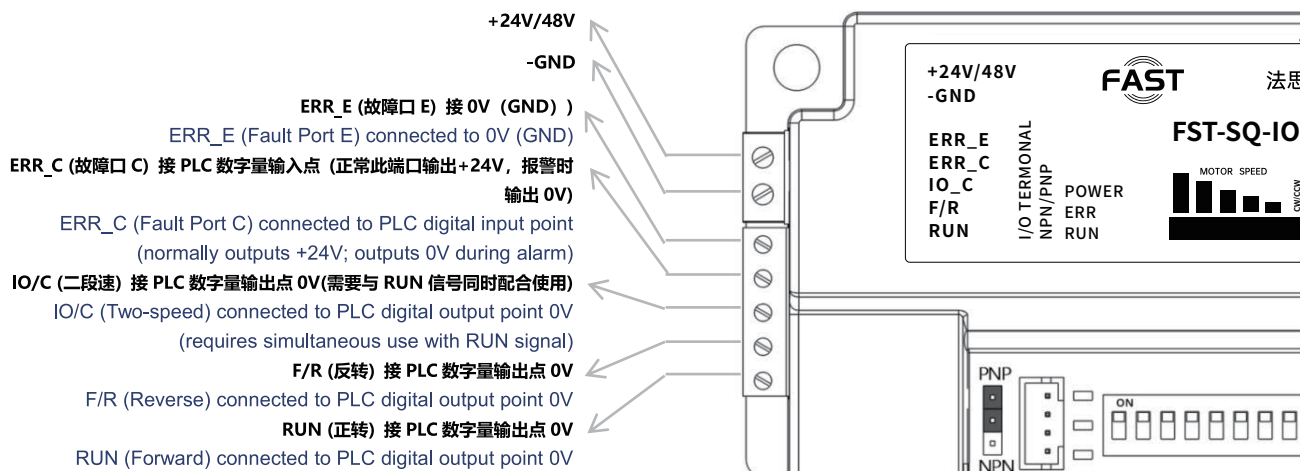

注：当控制回路与驱动主回路采用隔离电源分别供电时，必须将两个电源的 0V 参考地（-V 端）进行互联，避免电势差造成信号干扰。

Note: When the control circuit and the drive main circuit are supplied by separate isolated power sources, the 0V reference ground terminals (-V terminals) of both power supplies must be interconnected to prevent signal interference caused by potential differences

九、外形尺寸、安装孔位

External dimensions, mounting hole positions

1、外形尺寸 External dimensions

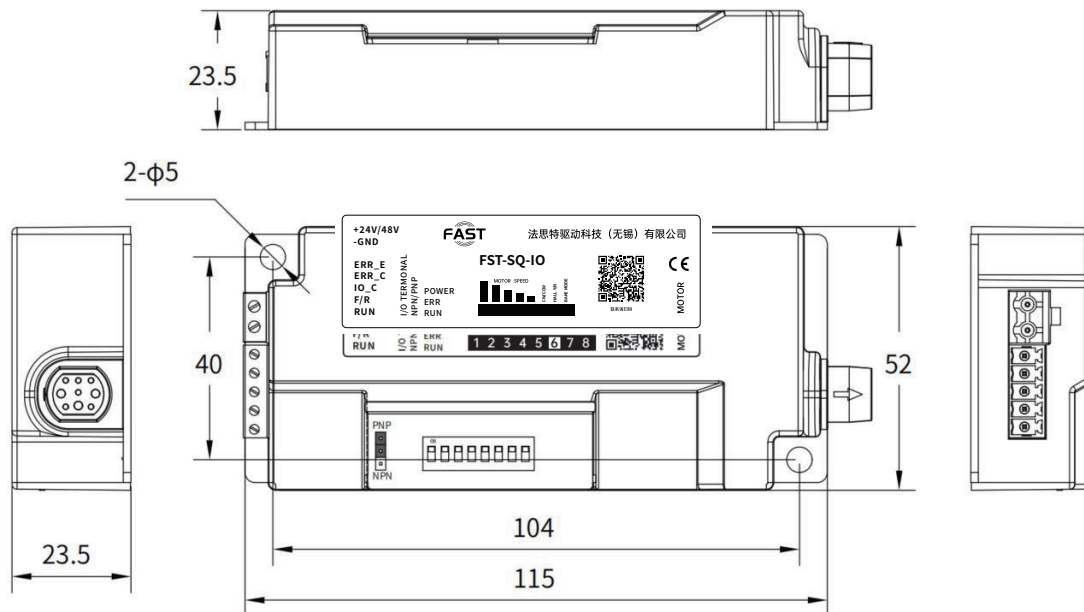

2、安装孔尺寸 Mounting hole dimensions:

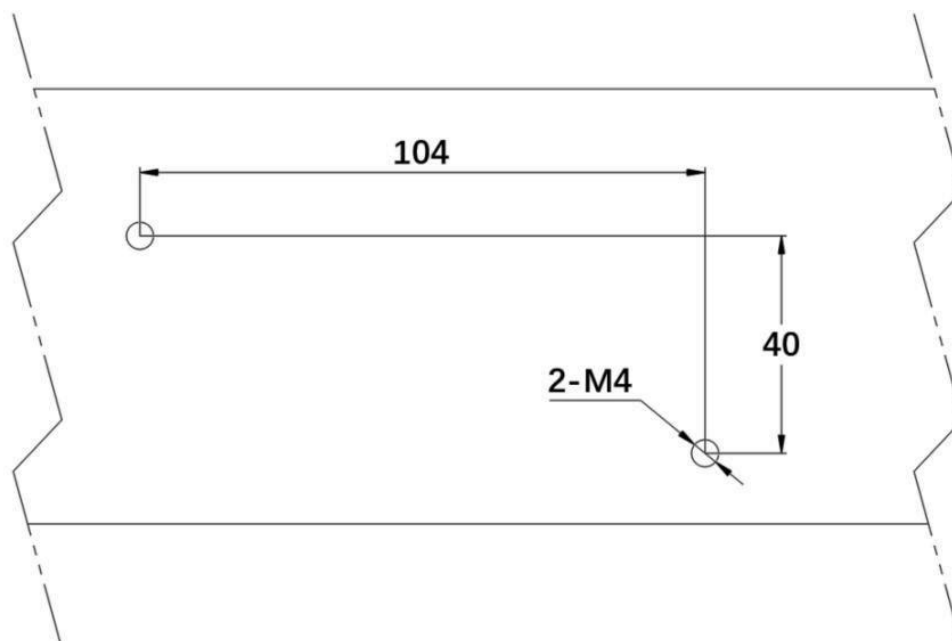



法思特-替代外挂电机的大负载输送电辊筒品牌

FAST-The brand of heavy-load drum motor that replace the traditional external motor



法思特驱动科技(无锡)有限公司
Fast Drive Technology(Wuxi) Co.,Ltd.

Add:江苏省无锡市经济开发区大通路 509 号

Tel:+86 15861693726/18036023240

E-mail:kongliang@wxfast.net

F-Web:www.wuxifast.com



扫码联系咨询